

StreetCurling - MCSZ Hivatal

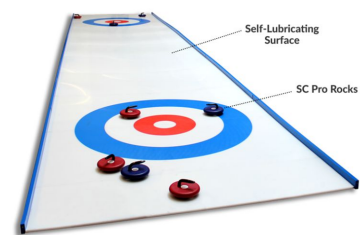

LOGÓ-val kapcsolatos kérdés:

Bad news: we cannot put logos on the "ice" of the Pro rink. It is synthetic ice and the stones actually slide on it. They do not use bearings or wheels underneath. If we put decals or stickers on the ice, the stones will not slide properly on them, and will also tear them. You can put some decals in the corners and in areas where the stones won't frequently slide, but that is about it. My recommendation is to put your logo and advertisements around the rinks, on signage, or we even now have these new customizable mats:

<https://twitter.com/rocksolidcurl/status/1097569334279458816?s=21>

We can make these rubber mats with your logo on them, but they would need to ship from Canada. I believe the price is around \$1,200 but we will of course offer a much lower price for WCF partners. They are brand new so we haven't finalized everything with them yet. The images are from the first event we did with them last weekend. They are a bit wrinkled because they are on snow. On a flat floor they will lie flat as well. They are also good for people to stand on, so it keeps the rink cleaner. They also catch the stones that go off the edge and prevent them from getting damaged.

We also have a template for the stones, where you can print decals with your logo and place them on the top of the stone. The body of the stones are the same as the FloorCurl stones you have, so you can do this with your current stones as well. Just let me know if you want the template and I can send it to you.

Szállítás + költség

Good news: with the Pro rink we can get a much lower shipping rate as we can send a rink to you directly from our factory in Germany.

That payment schedule will work for us. \$5,000 + shipping, \$4,000, \$3,000 USD.

WCF will pay us directly but the commercial invoice will show the goods coming from Germany, not Canada. This is how it has worked for other EU customers and they have not had to pay duty.

We are working on getting a shipping quote but for the application it is probably best to estimate it at around 500 USD for now, that will be a safe number.

A StreetCurling érzékenysége:

As long as it is used properly it will not be damaged and is very durable. The biggest maintenance issue is it will require simple cleaning from time to time but if you do not allow people to walk on it then it will require less cleaning. Like real ice, the stones will slide better when it is cleaner.

Eventually the steel "bullets" under the stones will wear down and need replacing but if you are not using it every single day this will take a long time to happen, likely years.

The "ice" is UV treated so it is safe to be in the sun, rain, snow, etc. But again, the more you have it in rain and snow, the dirtier it will be. You just need to clean it after. When you buy it we will send assembly instructions, cleaning info, etc.

Mérete:

Rink Dimensions

Single-Ended Rink Dimensions:
With border: 8.05 m x 2.05 m (26.4' x 6.7')

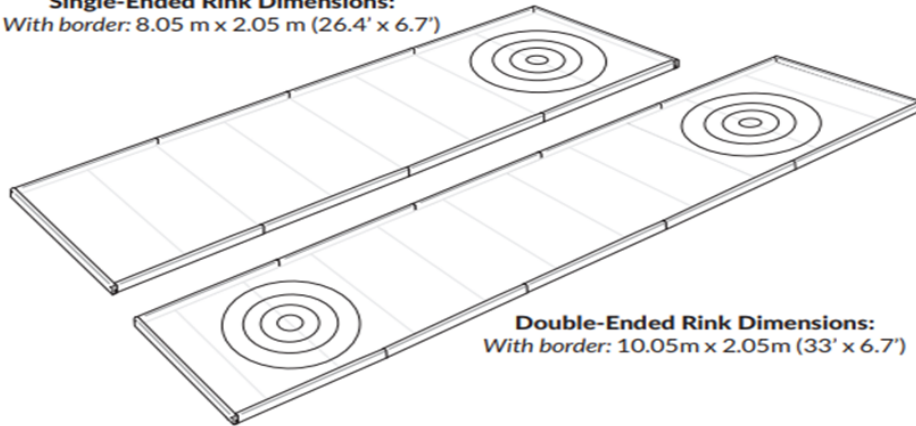

Double-Ended Rink Dimensions:
With border: 10.05m x 2.05m (33' x 6.7')

Shipping Dimensions

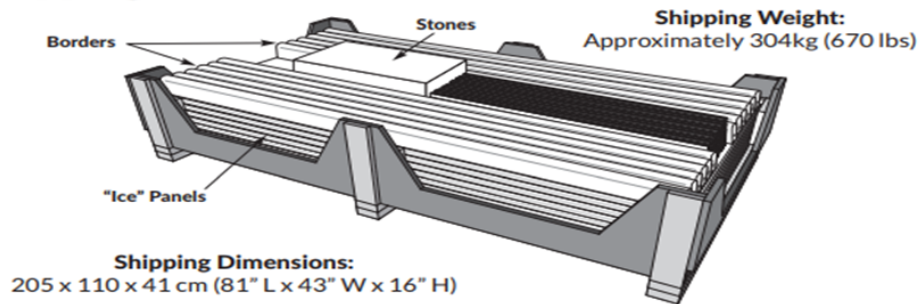

Összefoglalva:

Standard Rink Size	10m (33') long x 2m (6'7") wide
Branding Options	Limited
Setup	2 People, 1 Hour
Tools Required	3-4 Common Tools
Gameplay	Ideal for playing the sport
Stones Included	8 Pro Stones (4 red, 4 blue)
Stone Motion	Slides - like a real curling stone!
Stone Performance	Very Consistent
Type of Stones	Pro Stones (Smaller, Best Fit)



2019.04.04. meeting

Résztevők: Deák György, Fóti Balázs, Kiss Bálint, Kovács Zsuzsanna

PRO	CONTRA
profitot termel (használatáért pénzt kérünk) <ul style="list-style-type: none">• céges rendezvényeket tudunk értékesíteni• baráti társaságok (társas jellegű elfoglaltság)• buli curling	rongálódás veszélye, őrizni szükséges
	értékesítő kell mellé, informálás kell

Informálás: streetcurling honlap, rendezvényszervező cégek, informatív informálás - könnyű szabályok.

Előnyünk, ami a hátrányunk: "ilyen még nem volt".

Rongálás: köré, fölé építés.

Helyszín ötletelés:

- Lupa Beach (jó közönség)
- Jégart (jó értékesítés)
- Mammut tető (kreatív, izgalmas)

Olyan helyszíneket keresünk, ahol a rongálás lehetősége minimális, az információ átadása egyszerű. Nincs bérleti díj (bevétel megosztás lehetősége). Lokálisan könnyen megközelíthető. Eladható.

Árazás:

- per fő/félóra.